

About Submarine Telecommunications Cables

Communicating via the ocean

© International Cable Protection Committee Ltd



Contents

- A brief history
- What & where are submarine cables
- Laying & maintenance
- Cables & the law
- Cables & the environment
- Effects of human activities
- The future

A Brief History - 1

- 1840-1850: telegraph cables laid in rivers & harbours; limited life, improved with use of *gutta percha* insulation c.1843
- 1850-1: 1st international telegraph link, England-France, later cables joined other European countries & USA with Canada
- 1858: 1st trans-Atlantic cable laid by *Great Eastern*, between Ireland & Newfoundland; failed after 26 days & new cable laid in 1866

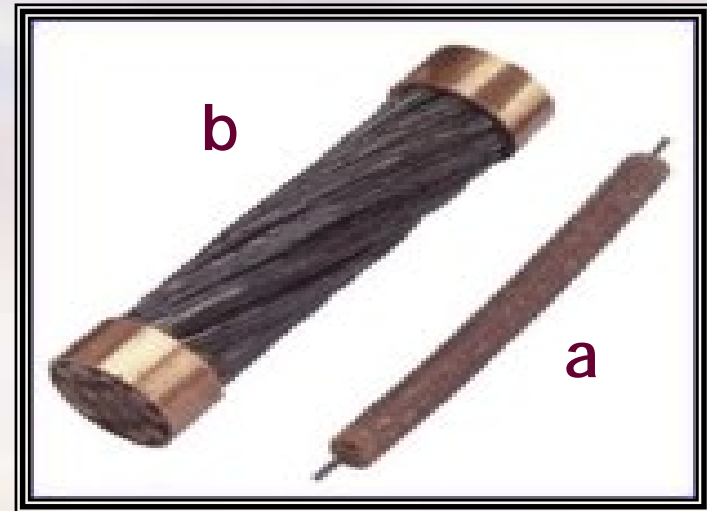

1850 (a) and 1851 (b) cables from UK-France link. Courtesy: BT



Great Eastern off Newfoundland. Courtesy: Cable & Wireless

A Brief History - 2

- 1884: First underwater telephone cable service from San Francisco to Oakland
- 1920s: Short-wave radio superseded cables for voice, picture & telex traffic, but capacity limited & subject to atmospheric effects
- 1956: Invention of repeaters (1940s) & their use in TAT-1, the 1st trans-Atlantic telephone cable, began era of rapid reliable communications
- 1961: Beginning of high quality, global network
- 1986: First international fibre-optic cable joins Belgium & UK
- 1988: First trans-oceanic fibre-optic system (TAT-8) begins service in the Atlantic

What & Where are Submarine Cables

Early telegraph cable

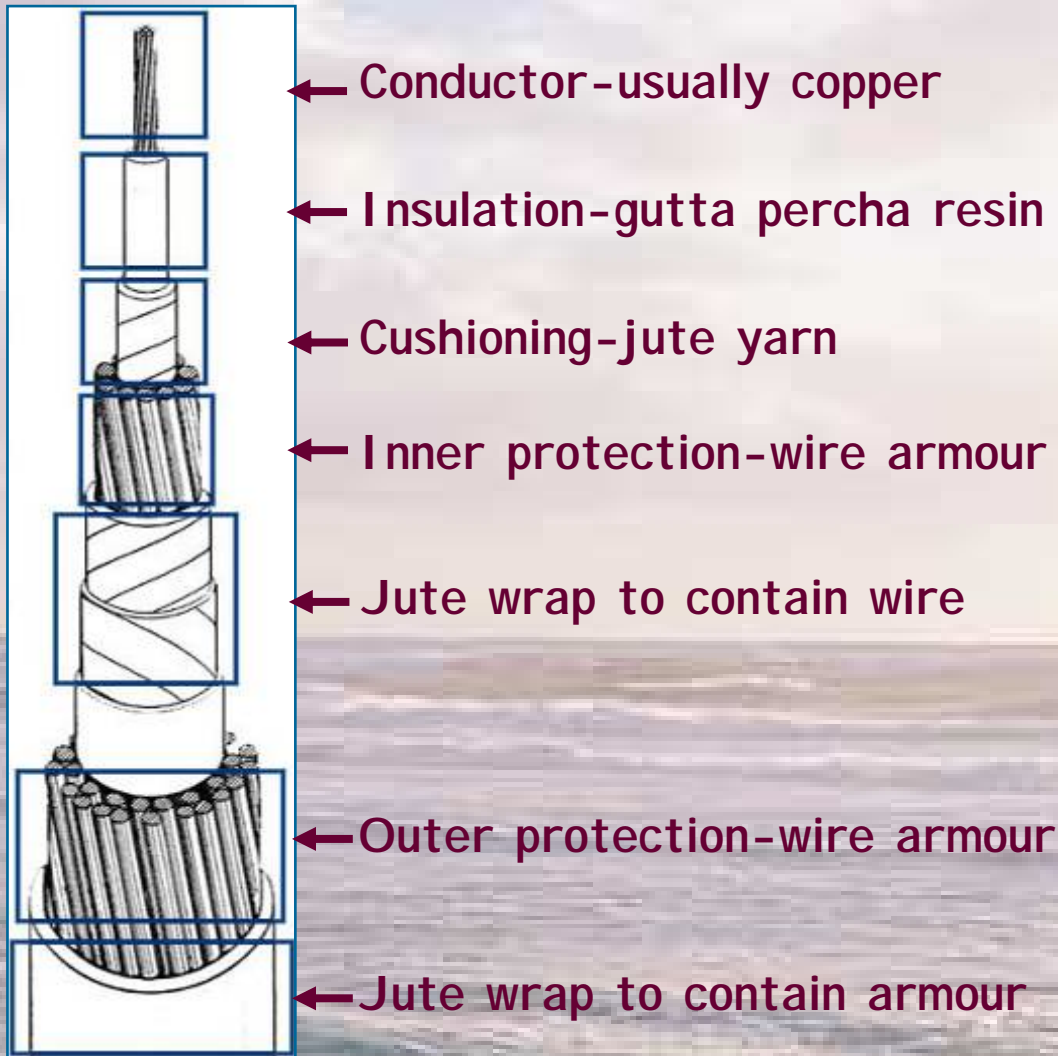

Harvesting gutta percha resin
Courtesy: PorthcurnoTelegraph Museum



Atlantic cable 1866
Courtesy: PorthcurnoTelegraph Museum

Modern Submarine Cable

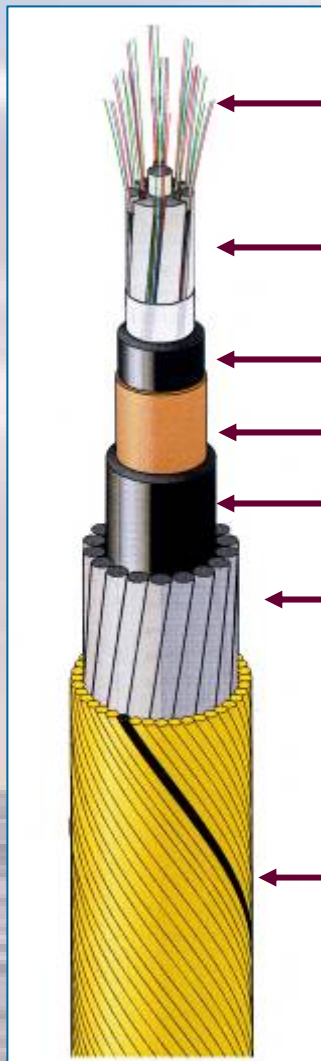

← Optical fibres - silica glass

← Core for strength & fibre separation - polyethylene/fibreglass

← Jacket - polyethylene

← Conductor - copper

← Jacket - polyethylene

← Protective armour - steel wire

← Outer protection & wire containment - polypropylene yarn

Courtesy: Ericsson

Construction varies with manufacturer & seabed conditions. Cables may have no armour in stable, deep-ocean sites or 1 or more armour layers for energetic zones, e.g. coastal seas

How Submarine Cables Work

- Modern submarine telecommunications cables rely on a property of pure glass fibres, whereby light is transmitted by internal reflection
- Because the light signal loses strength en route, repeaters are installed along the cable to boost the signal
- New systems rely on optical amplifiers - glass strands containing the element, erbium. Strands are spliced at intervals along a cable & then energized by lasers that cause erbium-doped fibres to "lase" & boost optical signals

Typical Submarine Cable System

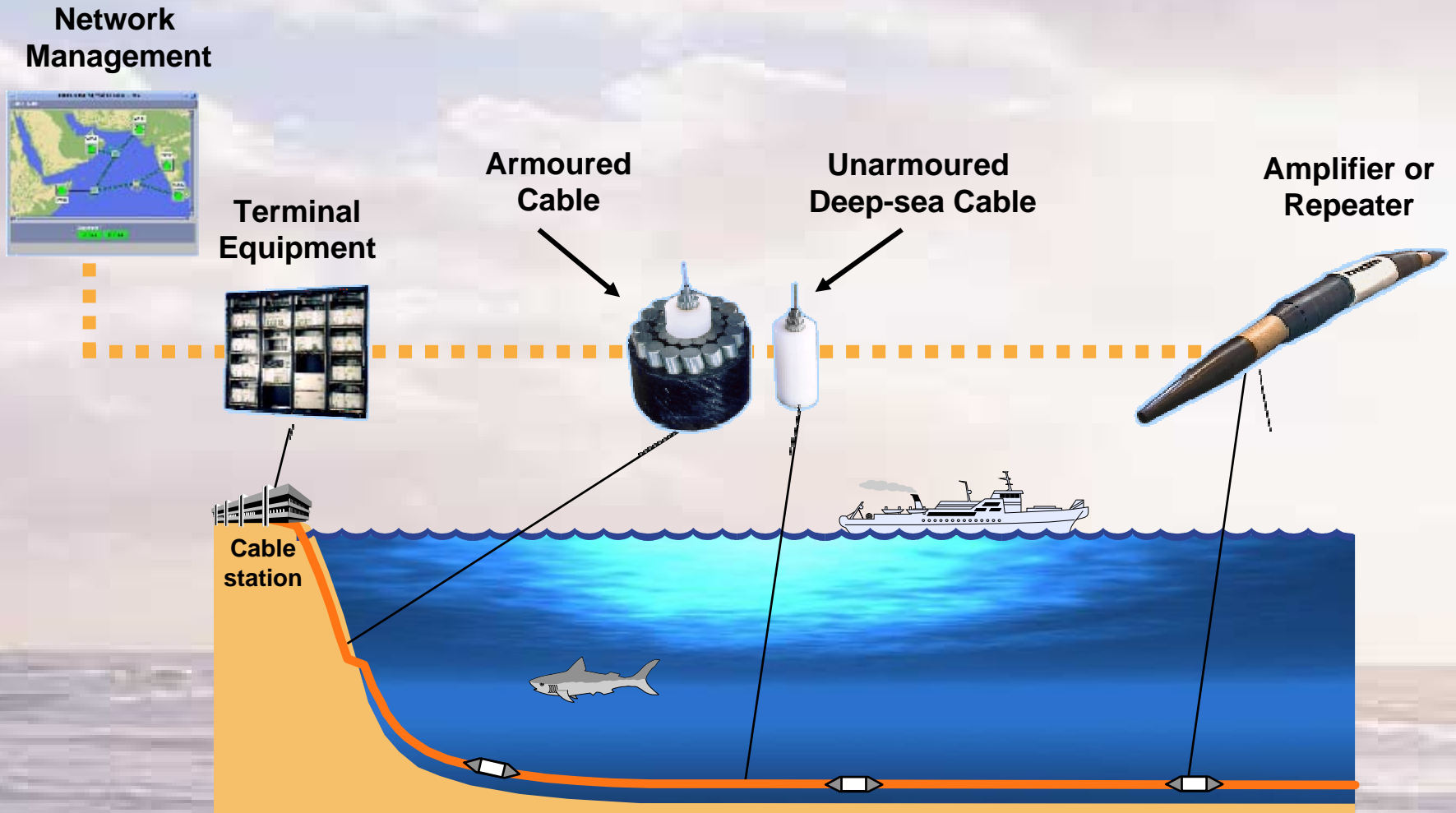

Courtesy: U.K. Cable Protection Committee & Alcatel Submarine Networks

Comparing Old & New

Old Cable Systems:

- 1866: First trans-Atlantic cable carried telegraph messages at 7 words a minute & cost £20 for 20 word message
- 1948: Telegram costs reduced to 4 pence a word for transmission across the Atlantic
- 1956: First trans-Atlantic telephone cable (TAT-1) initially had capacity of 36 telephone calls at a time; calls costing US\$12 for first 3 minutes

Modern Cable Systems:

- 1988: First Atlantic fibre-optic cable, TAT-8, had capacity for 40,000 simultaneous phone calls, 10 times that of the last copper cable
- Today: Each fibre pair within a cable has the capacity to carry digitised information (including video) that is equivalent to 150,000,000 simultaneous phone calls

Cable Size

- Cables are small; deep-ocean types without protective armour are typically 17-20 mm diameter, similar to that of a garden hose or beer bottle cap
- Armoured fibre-optic cables may reach 50 mm diameter
- In contrast, submarine oil/gas pipes reach 900 mm diameter, & fishing trawls typically range over 5,000 - 50,000 mm width
- Cable lengths vary; one of the longest is the SEA-ME-WE 4 system at ~20,000 km

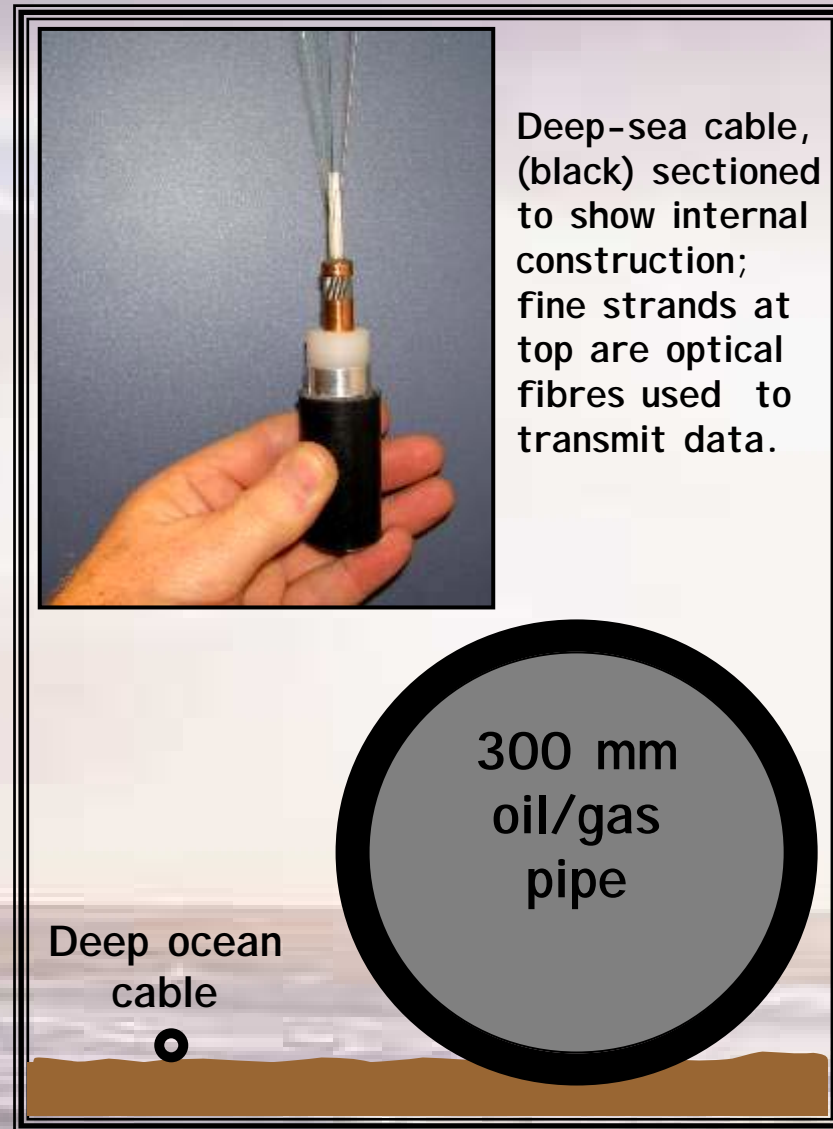

Modern fibre-optic cable in hand (for scale) & relative to 300 mm diameter subsea pipe.

Cables & Satellites

Advantages of cables

- High reliability, capacity & security
- None of the delays present in satellite traffic
- Cost-effective on major routes, hence rates cheaper than satellites

Submarine cables carry >95% of international voice & data traffic

Advantages of satellites

- Suitable for disaster-prone areas
- Provides wide coverage for mobile subscribers
- Suitable for linking isolated regions and small island nations into the international telecom network

Satellites carry <5% of international voice & data traffic

Strategic Importance of Submarine Cables

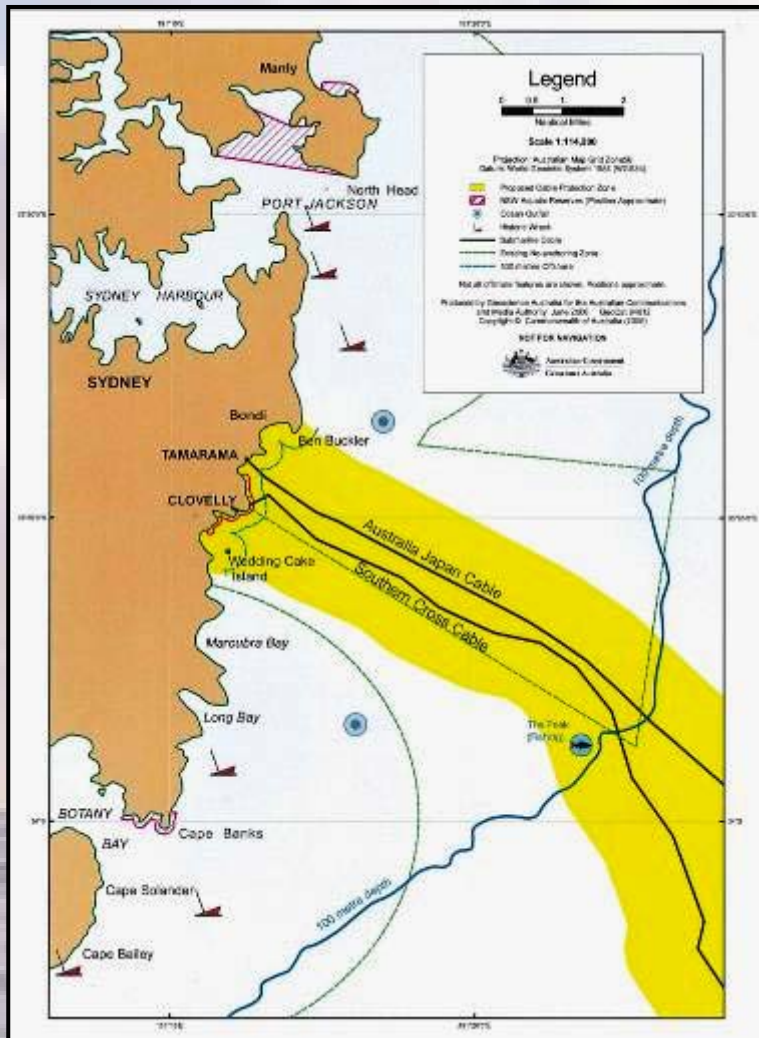

- Submarine cables are the backbone of the international telecommunications network
- Almost 100% of transoceanic Internet traffic is sent via submarine cable
- The submarine cable network is designed to be resilient, however faults can disrupt activities we take for granted – banking, airline bookings, internet shopping, education, health, defence, and of course, our communication with one another
- Many Governments now recognise the strategic value of submarine cables and are taking stronger measures to help protect them

New protection zones (yellow) proposed for Australia where value of submarine cables to economy is assessed at \$A5 billion. [Courtesy: Australian Communications & Media Authority](#)

International Cable Routes

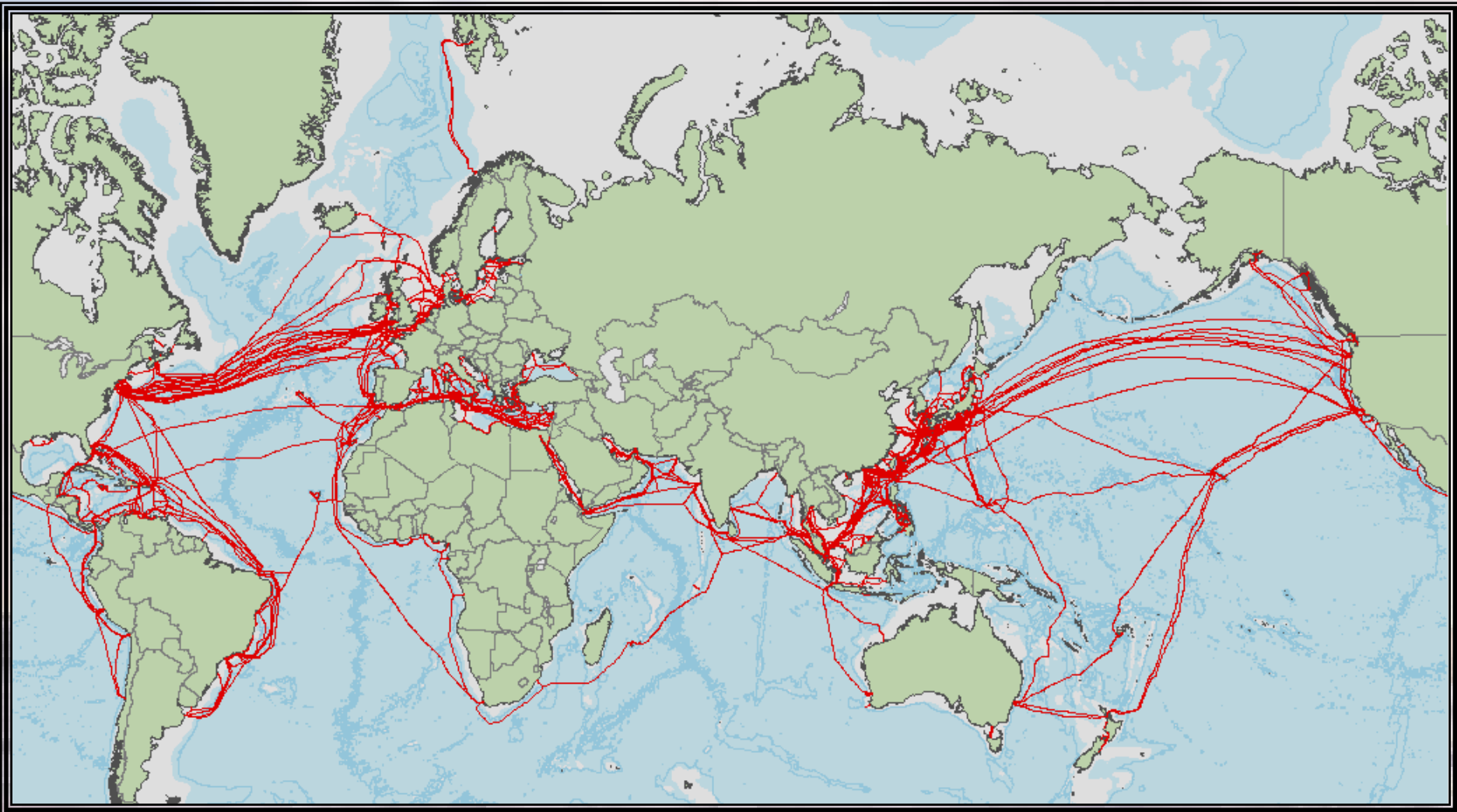

Courtesy: Global Marine Systems Ltd

Coastal Cable Routes

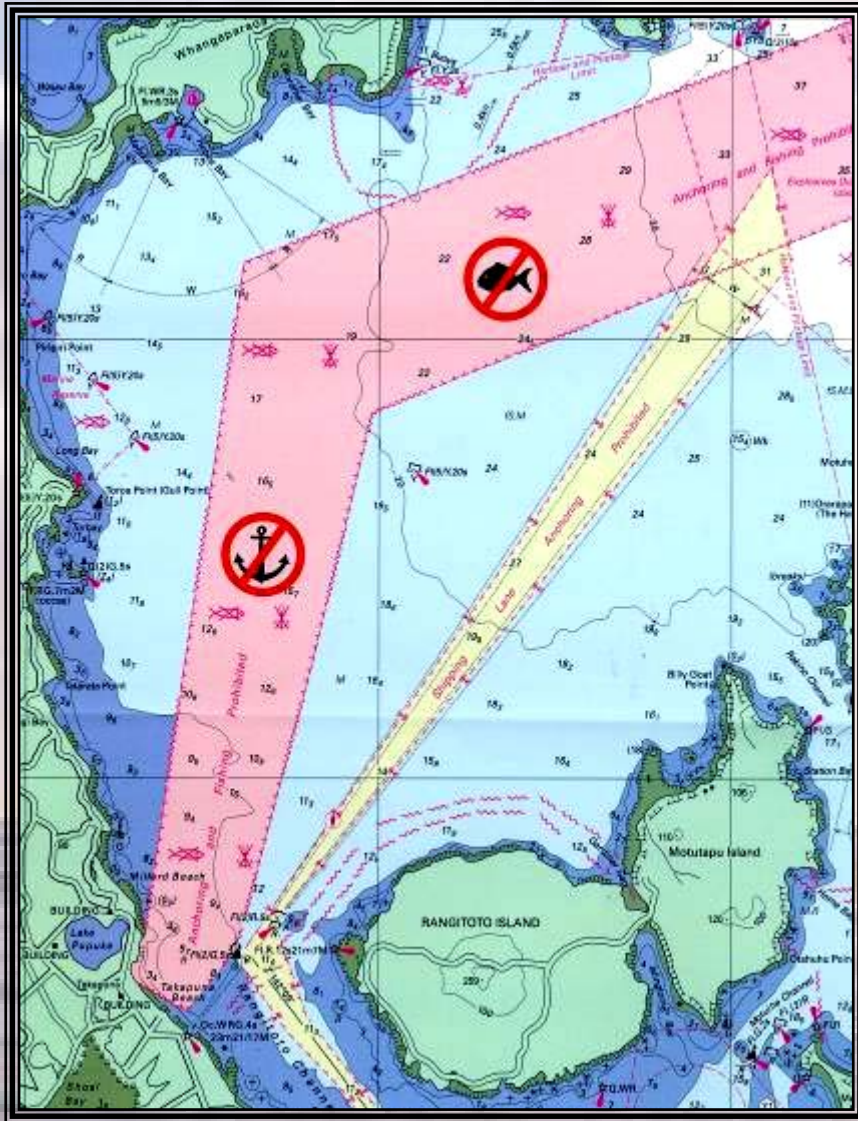

- Nearshore, cables need protection from shipping, fishing & other activities
- To reduce risk, cables are identified on nautical charts and may be placed within a “protection zone”
- A zone is a legal entity where activities harmful to cables are banned
- Cable burial in water depths to 1500m is also a key protective measure

Protection zone for Southern Cross cable terminal, NZ. Courtesy: Telecom New Zealand

Laying & Maintaining Cables

- Laying typically involves:
 - Selection of route
 - Assessment of potential impacts of cable laying on environment
 - Full survey of route & its final selection
 - Design cable to meet environmental conditions
 - Laying of cable
 - Notification of cable position
 - In some cases, a post-lay survey
- If repair or replacement needed, an operational plan may be required along with requirements outlined above

Cable Route Survey

Cable routes are carefully surveyed to minimize environmental impacts and to maximize cable safety

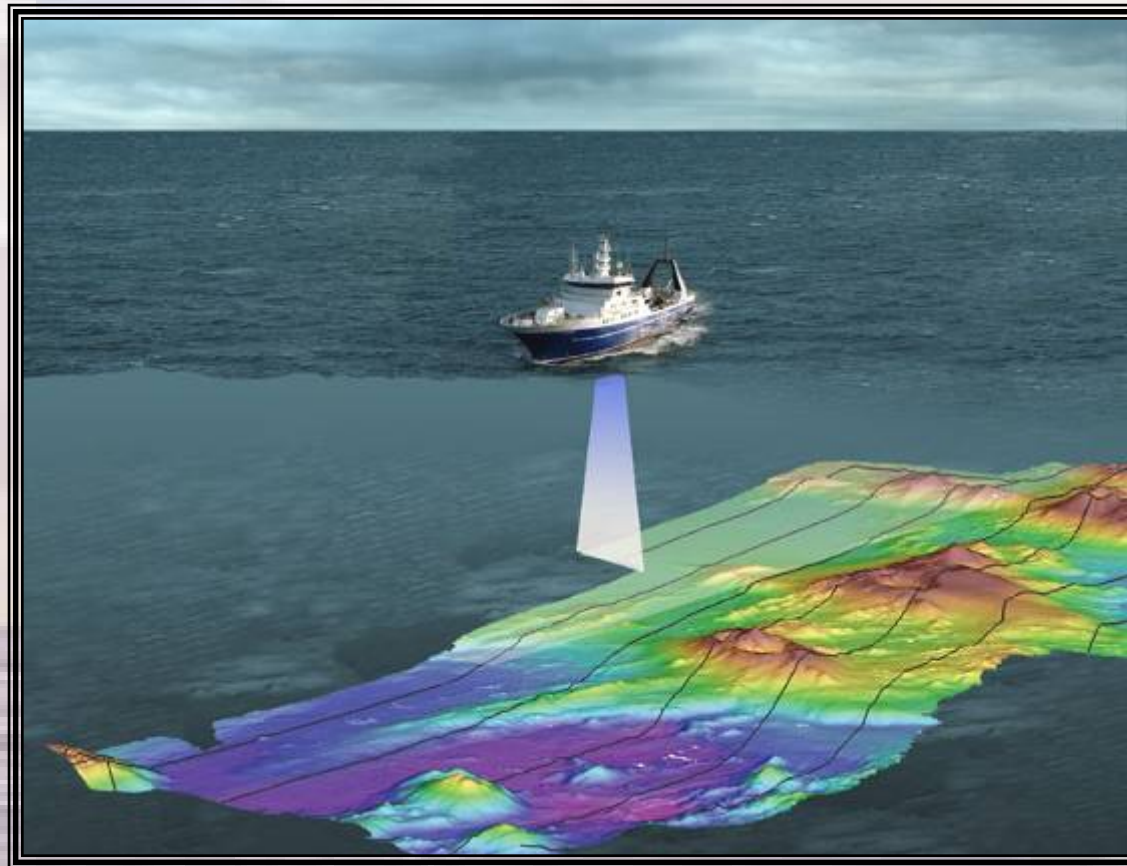

Seabed mapping systems accurately chart depth, topography, slope angles & seabed type

Courtesy: NIWA

Cable Laying

- Purpose built ships accurately place cables on or under the seabed, guided by the route survey
- Shallow water laying may be aided by divers; deep water laying may involve remotely operated vehicles

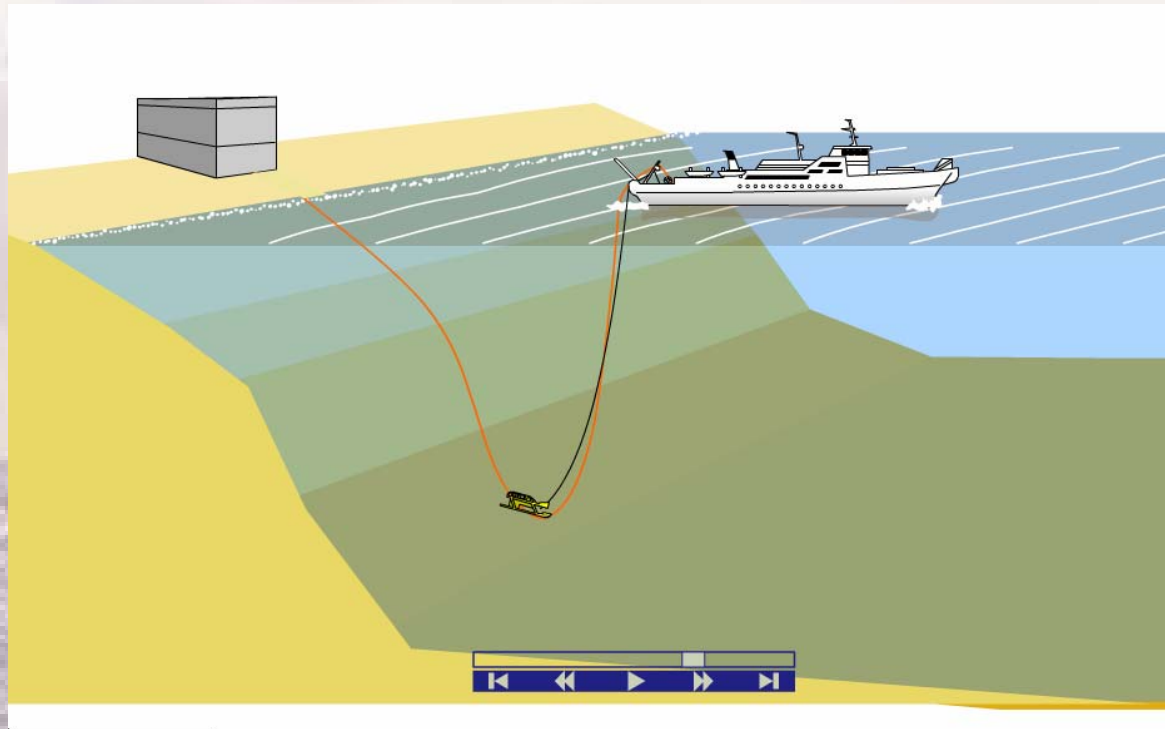

Courtesy: Alcatel Submarine Networks

Cable Ships Through Time

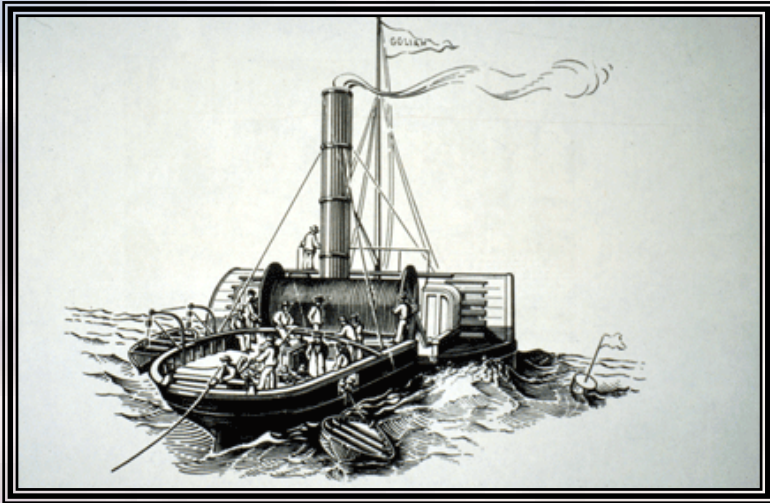

1850/51: *Goliath* deploys 1st international cable, UK-France
Courtesy: [Illustrated London News](#)

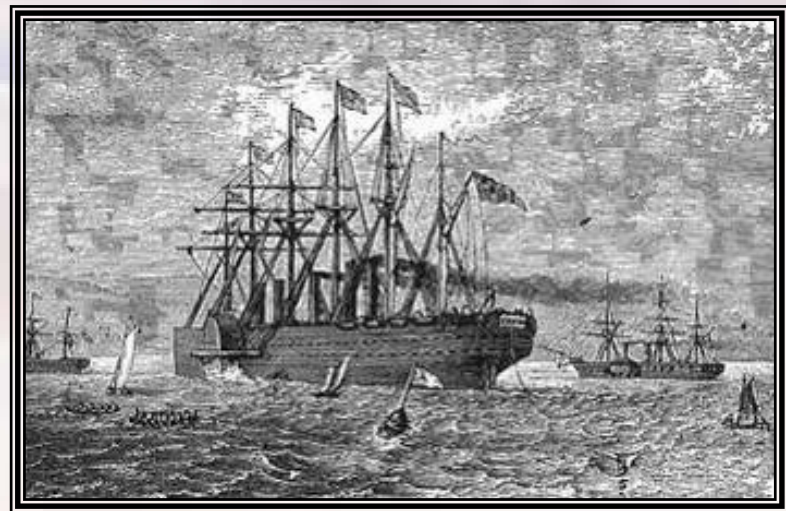

1866: *Great Eastern*, laying cable off Newfoundland
Courtesy: [Canadian Government](#)



1900: *John Pender* named after pioneer cable maker
Courtesy: [Cable & Wireless](#)



1992: *KDD Ocean Link*
Courtesy: [KDDI](#)

Cable Burial - 1

- Cables may be buried in a narrow (<1 m wide) trench cut by water jet or plough; the latter lifts a wedge of sediment just enough to insert a cable below
- Ship's speed during burial varies with cable & sea conditions; speed for an armoured cable is ~0.2 km/hr; for non-armoured cable laid on a flat seabed in calm weather, laying speeds can reach 12 km/hr



Sea plough & cable ship about to bury cable Courtesy: Seaworks, NZ

Cable Burial - 2

- Cables typically buried 1-3.5m under the seabed (can extend to 10m) to protect from fishing & other activities
- Burial may extend from shore out to ~2000m water depth, which will protect submarine cables from the majority of trawl fisheries
- Burial may locally disrupt the seabed along a narrow path & form turbid water, whose extent relates to burial technique, seabed type & wave/current action
- In the absence of cable-based studies, analysis of seabed disturbance by other activities suggests impacts short-lived (months) where waves/currents are active, but possibly longer-lived in deeper, less turbulent water

Cable Recovery

- Cables have to be recovered from the seabed for repairs, replacement or removal
- Recovery may result from damage, failure, age/redundancy or clearance of congested routes

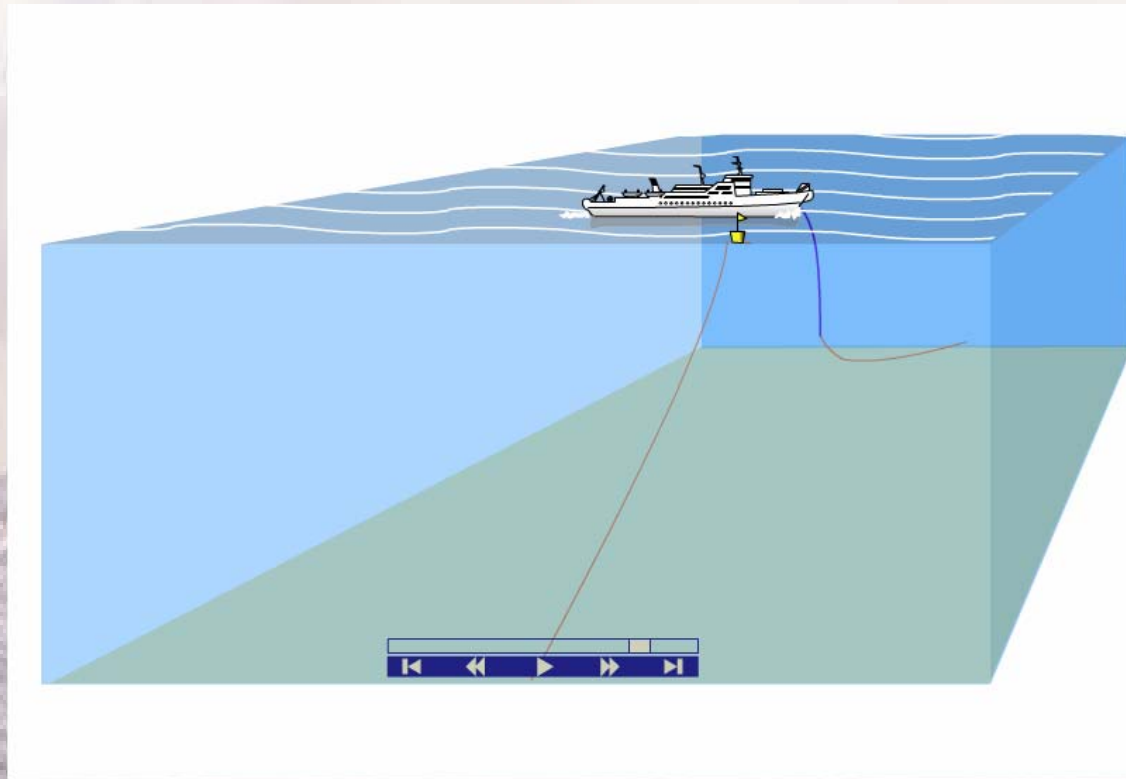

Courtesy: Alcatel Submarine Networks

Cable Recovery in 1888

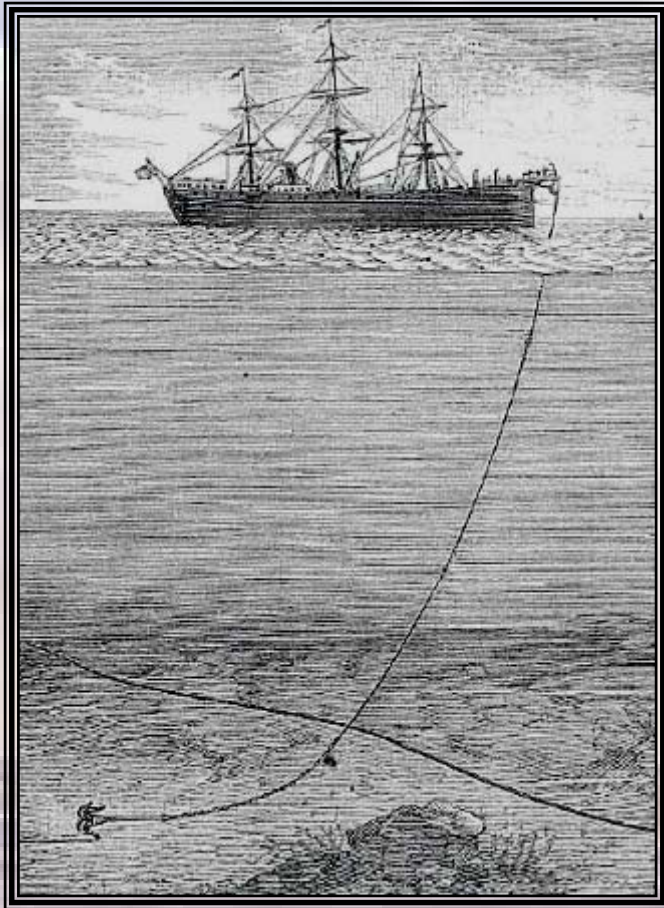

Cable ship trailing grapnel to retrieve cable

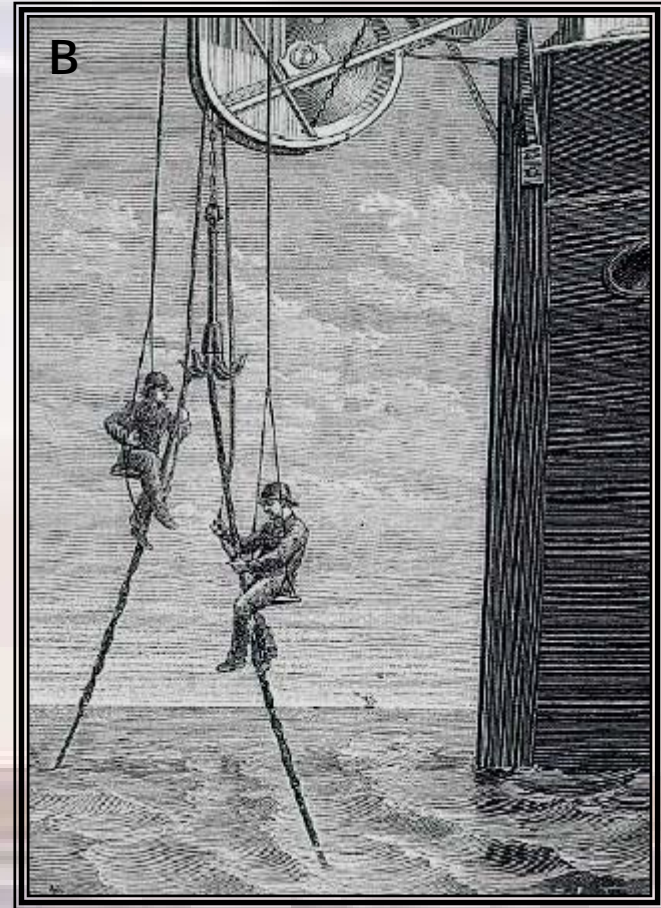

The securing of the cable ready for repair

Courtesy: *Traité de Télégraphie Sous-Marine* by E. Wüschendorff, 1888

Cables & the Law

Recognizing the value to humanity of international communications, cables are protected by international treaties:

- The International Convention for Protection of Submarine Cables (1884)
- The Geneva Conventions of the Continental Shelf and High Seas (1958)
- The United Nations Law of the Sea Convention (1982)

Modern international law extends the special status of international cables to all uses:

- **Telecommunications**
- **Power**
- **Scientific**
- **Military**

The International Treaties provide:

- Freedom to lay, maintain, and repair cables outside of a nation's 12 nautical mile territorial sea
- Obligations on Nations to impose criminal and civil penalties for intentional or negligent injury to cables
- Special status for ships laying and repairing cables
- Indemnification for vessels which sacrifice anchors or fishing gear to avoid injury to cables
- Obligations on owners with new cables that are laid over existing cables and pipelines to indemnify repair costs for any damage caused
- Universal access to national courts to enforce treaty obligations

Cables & the Environment



ATOC/Pioneer Seamount scientific cable with attached anemones (*Metridium farcimen*) at ~140 m depth off California

Courtesy: Monterey Bay Aquarium Research Institute

- Professionally installed fibre-optic cables have a neutral to benign effect on the marine environment
- Their small diameter means that their “footprint” is small, especially when compared to submarine pipelines
- They are composed of non-toxic materials that are stable in sea water
- They provide substrates for marine organisms
- Recovered cables sometimes yield key specimens for scientific collections

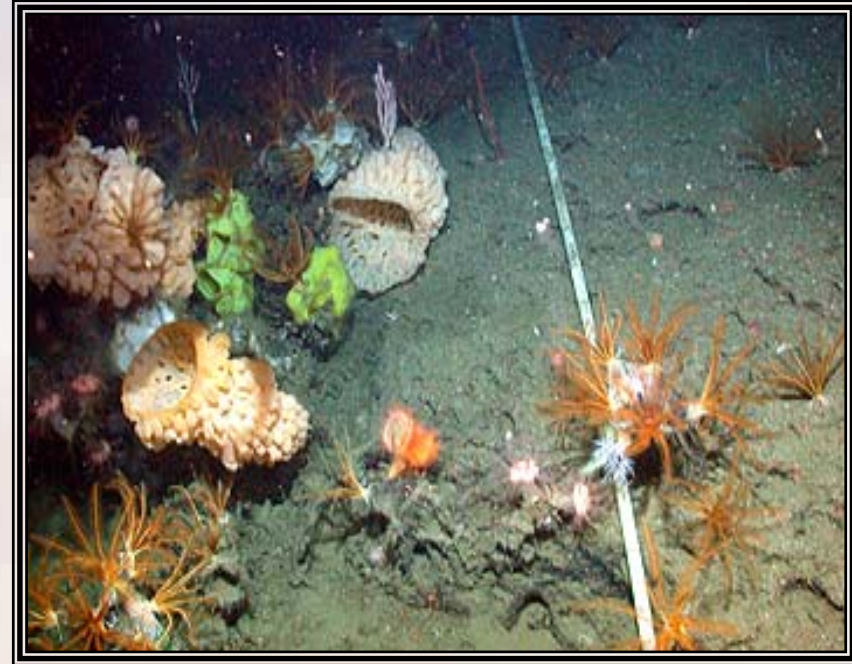

ATOC/Pioneer cable with marine life on & close to cable

Courtesy: Monterey Bay Aquarium Research Institute

Cables as Artificial Reefs

- Mounds of coiled cable form artificial reefs off Maryland & New Jersey
- Reefs attract a range of marine organisms from algae to fish
- Reef materials must be stable, non-toxic, last for 20-30 years & provide habitats



Maryland cable reef highlighting biological growth, which may help biodiversity & fish stocks. Courtesy & ©: Compass Light

Cable Protection Zones as Sanctuaries

- Cable “protection zones” may act as marine sanctuaries to improve biodiversity & fish stocks
- An effective zone must contain habitats suitable for fish & other marine life, exist long enough for ecosystems to develop, & be policed to prevent illegal fishing

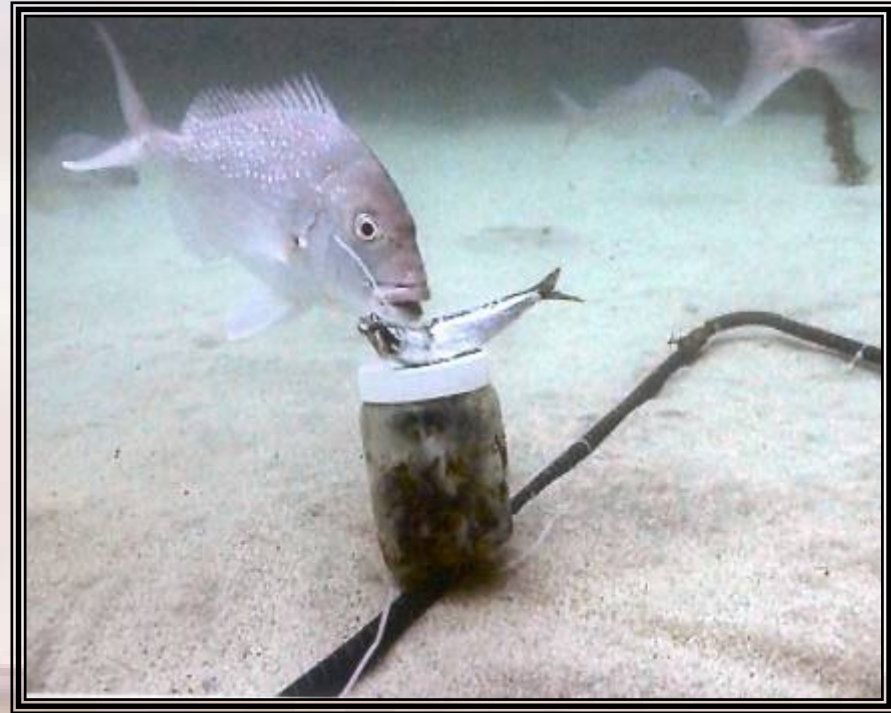

Experiment to count fish to test if a cable protection zone acts as a marine sanctuary *Courtesy: University of Auckland*

Observing the Ocean

- Ocean observatories are either underway or planned for long-term monitoring of the marine environment
- Observation sites will be linked via subsea cables that will allow data transfer to shore in real time
- Covering many parts of the world, observatories will detect & warn of natural hazards, measure ocean change under global warming, undertake research, & develop technologies

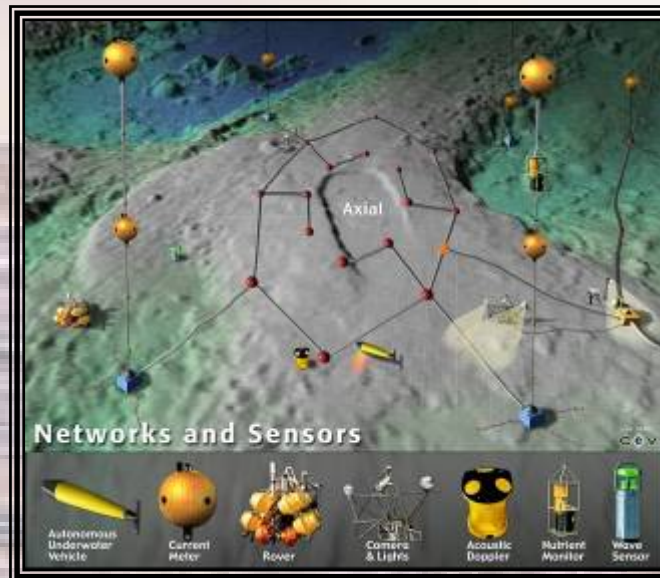
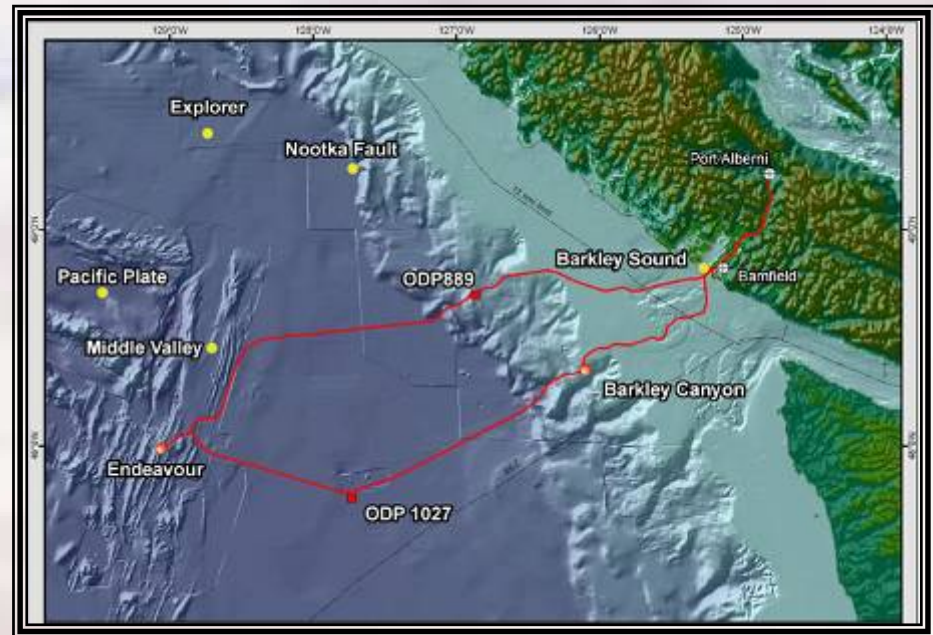

Neptune ocean observatory off Canada with planned sensors.

Courtesy: Neptune Canada

Marine Mammals

- Published cable fault data show that from 1877 to ~1960, 16 whale entanglements were noted - mainly involving sperm whales
- Since that period, there are no records of mammal entanglements
- This change may in part be due to improved materials and laying techniques. Compared to telegraph cables, modern cables are stronger, laid under tension with less slack, and are often buried below the seabed in water depths down to ~2000m

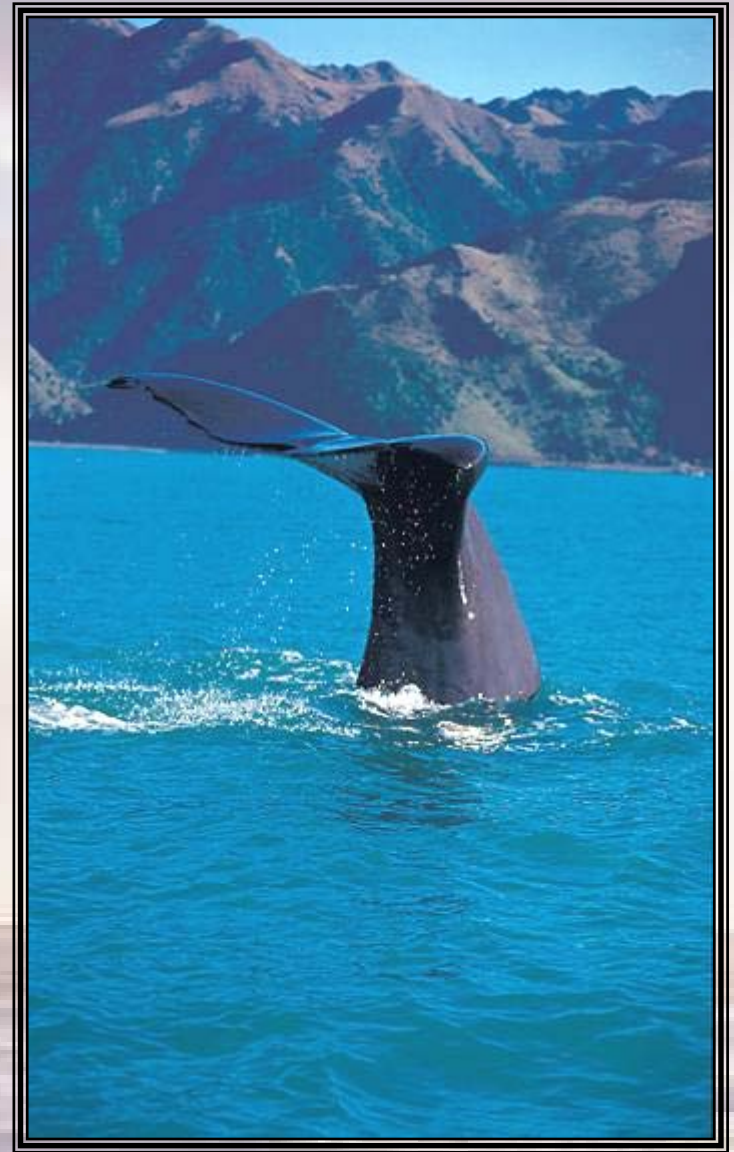

Sperm whale begins dive off New Zealand *Courtesy: NIWA*

Sharks & Other Fish

- At least 40 cable faults caused by shark [5] & “fish” bites [35]
- Attacks are verified by presence of fish teeth embedded in cable
- Faults caused by fish restricted mainly to telegraph cables (pre-1964), but in 1985-1987, 4 shark bites damaged Optican fibre-optic cable at 1060-1900 m depth
- Attacks may result from cable smell, colour, motion, electromagnetic field
- Attacks deterred by armouring or metal tape sheathing



Deep-sea shark, 4.6m long, at 640 m [2100'] depth [Courtesy: NOAA](#)

Effects of Natural Hazards

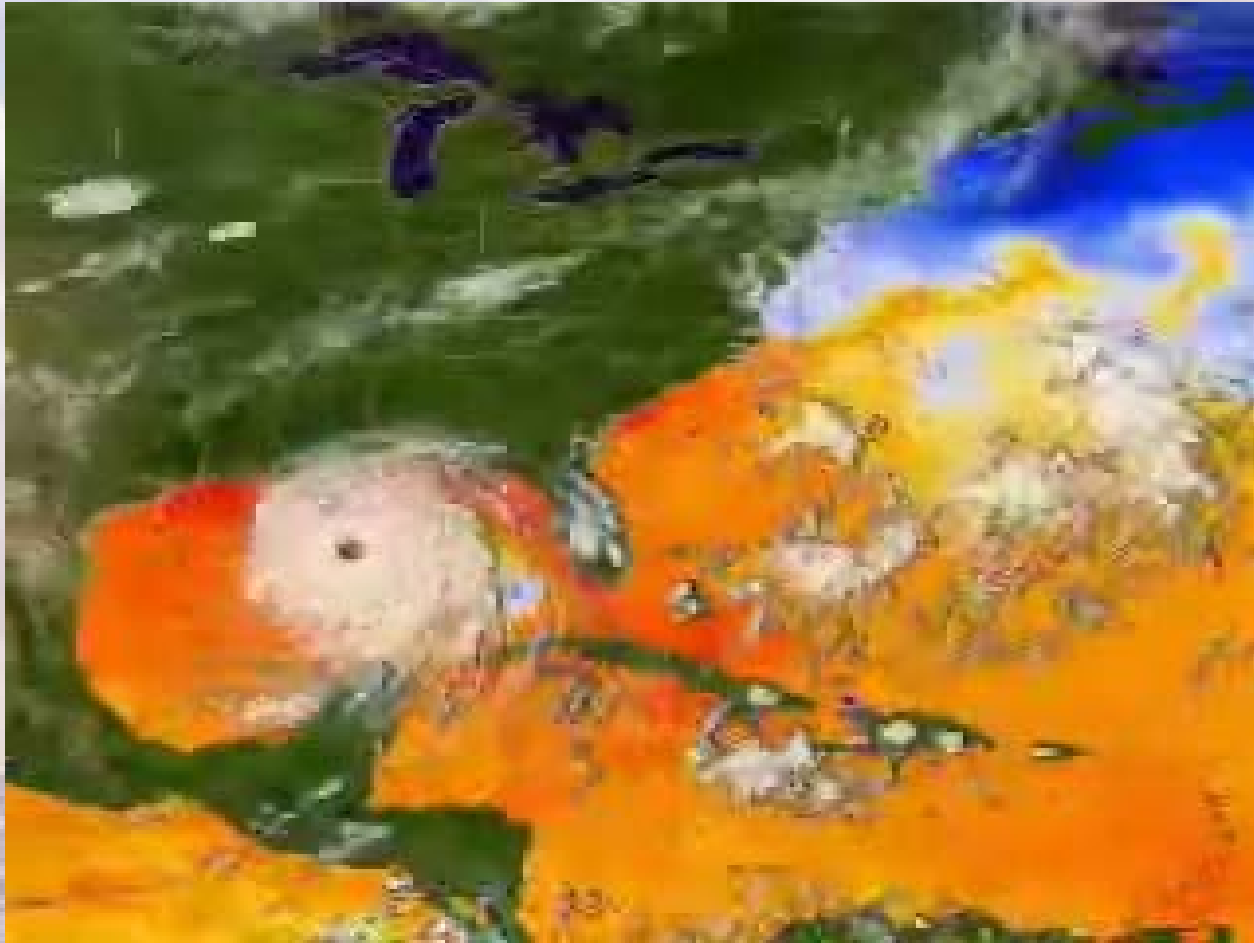

Katrina as a Category V hurricane, August, 2005. Such events affected cables by flooding coastal facilities, triggering submarine landslides, & forming strong, eroding currents/waves *Courtesy: NASA*

- Submarine cables are exposed to a range of natural hazards in all water depths
- In water depths less than ~ 1000m the main hazards are human activities; natural impacts cause <10% of cable damage
- In water depths more than ~1000 m, natural hazards dominate & include:
 - Submarine earthquakes, fault lines & related landslides - break or bury cables
 - Density currents - break or bury
 - Currents & waves - abrasion, stress & fatigue
 - Tsunami, storm surge & sea level rise - damage coastal installations
 - Extreme weather (e.g. hurricanes) - break or bury
 - Rarely, icebergs or volcanic activity

Hazards & Climate Change

Cables may be exposed to more hazards under global warming, via:

- Rising sea level due to thermal expansion of ocean & melting land-based ice sheets
- Increased windiness & related wave/current activity
- More intense hurricanes, cyclones, typhoons
- Changes in marine activities, e.g. commercial fishing

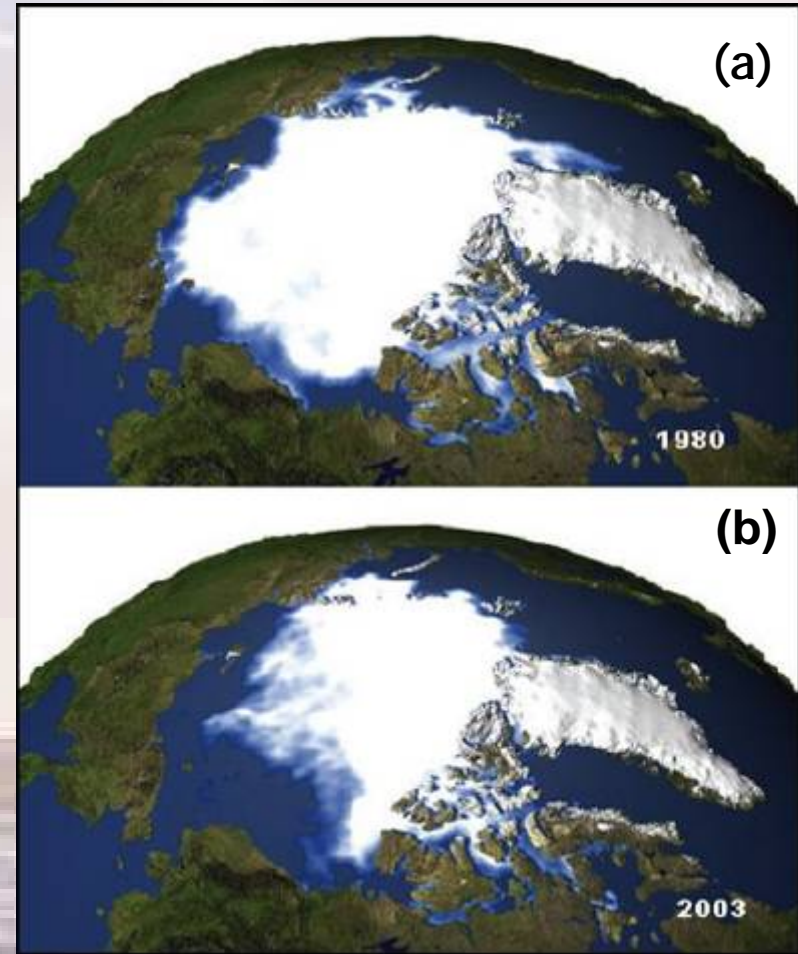

Reduced polar ice 1980 (a) & 2003 (b) emphasizing recent effects of warming *Courtesy: NASA*

Effects of Human Activities

Submarine cables come into increasing contact with other seabed users especially fishing & shipping industries

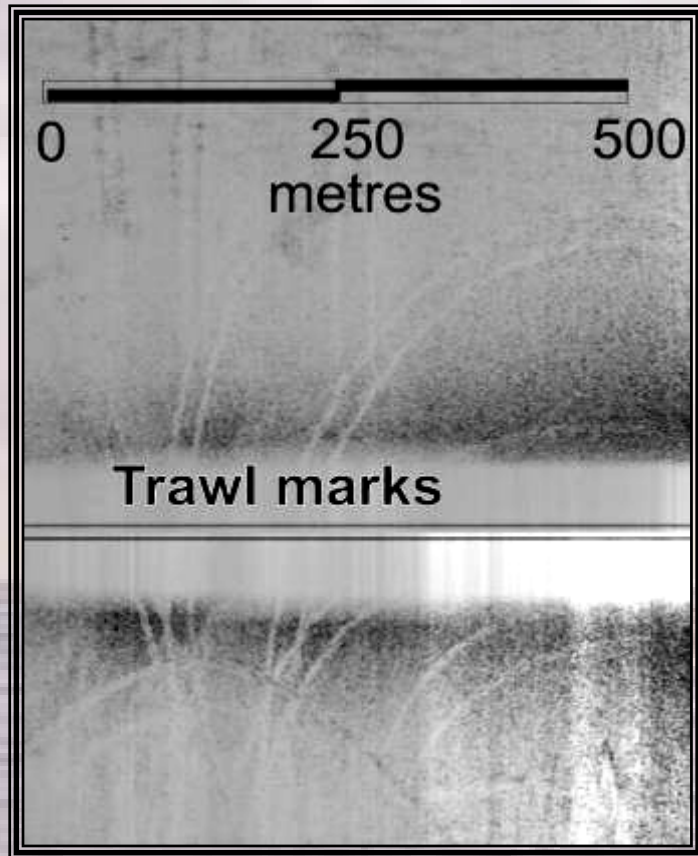

Sonar image of trawl scars, 25m wide, Nova Scotian shelf

Courtesy: A.Orpin, NIWA



Trawl scars, Chatham Rise

Courtesy: M. Clark, NIWA

- ~70% of all cable faults are from fishing & anchoring
- Natural hazards, including current abrasion & earthquakes, cause ~12% of faults
- Most faults occur in water depths less than 200 m & result mainly from human activities
- Faults in water deeper than 1000 m result mainly from natural causes

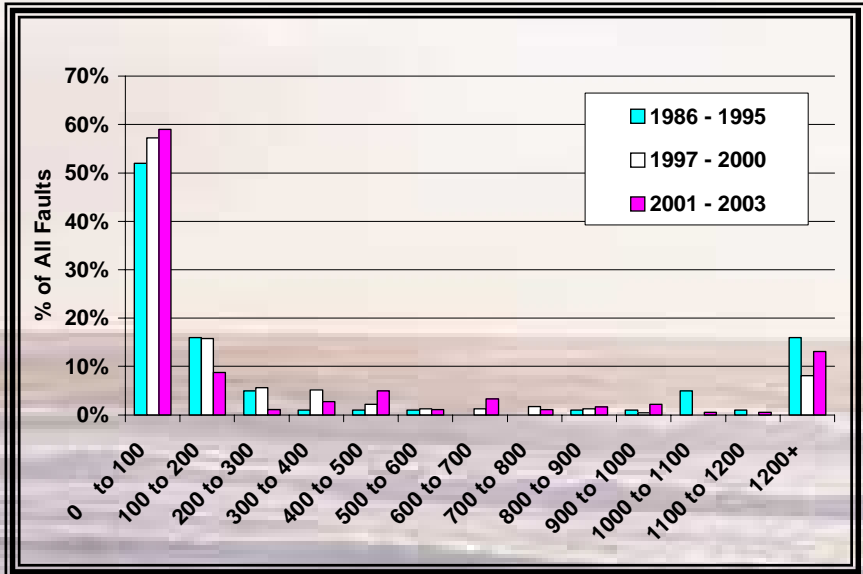
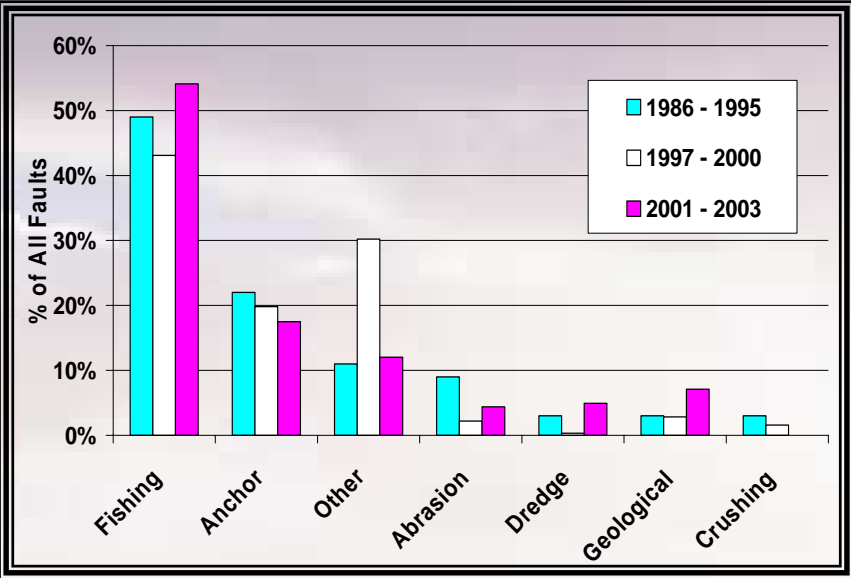

Fault summaries relating to Activity & depth

Courtesy: Submarine Cable Improvement Group

Damage from Fishing



Cable damaged
by trawling gear



Cable snagged & moved by trawling gear
Courtesy: Seaworks & Transpower NZ

Other Seabed Users

- Coastal seas are increasingly used for energy projects (wind, tide & wave power), resource extraction & environmental protection (marine sanctuaries; marine protected areas, etc.)
- ICPC Ltd strongly supports constructive interaction with other seabed users to ensure harmonious access to coastal seas & ocean



Offshore wind farm, Middelgrunden, Denmark. Courtesy & ©: LM Glasfiber

Submarine Cables and the Future

"Prediction is very difficult, especially about the future" : Niels Bohr

Law:

- Coastal State encroachment on traditional freedoms under UNCLOS to lay, maintain and repair international cables
- Resolution of Continental Shelf boundaries under UNCLOS
- Lack of national legislation to implement UNCLOS obligations to protect international cable infrastructure beyond territorial waters
- Restrictions on international cables without actual scientific basis to appease local constituencies, which regard cables as an alternative revenue source

Technology:

- Cable design & operations are constantly evolving. Future systems are expected to have even greater capacity and reliability
- Development of ocean observatories will rely on new cable technology including attached environmental sensors & docking modules for submarine survey vehicles to download data & recharge
- Cables, with sensors to detect chemical & physical changes, are planned for maritime & coastal defenses

Environment:

- Cable systems in some regions are likely face more natural hazards related to changing climate
- Climate change may also affect other marine activities such as fishing, with potential impacts on cables
- Measures to preserve biodiversity, ecosystems & resources via various protection zones in national waters & high seas, may impinge upon cable passage
- The ocean, especially coastal seas, will be subject to increased human activities such as expansion of renewable energy schemes

Glossary

- **Armour:** steel wires around cable for strength & protection
- **Coaxial cable:** Two concentric conductors separated by an insulator; enabled telephone calls over long distances using analog technology; short links in 1940s, first trans-ocean cable 1956
- **Fibre-optic cable:** Optical fibres encased in protective tube that also forms a power conductor for repeaters. Enables telephony, video and data communications over long distances using light with much greater capacity, reliability & signal quality; first international link installed from UK to Belgium in 1986
- **Gutta percha:** a naturally occurring resin, similar to rubber, used to insulate cables up to 1930s
- **Repeater:** Subsea devices that are required to boost the signal at intervals on long-haul cables; invented 1940s
- **Telegraph cable:** Copper wires insulated with gutta percha, wrapped in India rubber and steel wire; first submarine link 1850-1

NB: An excellent list of standard definitions can be found at www.scig.net

Contacts

Technical Content & General Enquiries:

ICPC Secretariat

Email: secretary@iscpc.org

Environmental Content:

Professor Lionel Carter

Email: lionel.carter@vuw.ac.nz

Legal Content:

Mr. Doug Burnett

Email: douglas.burnett@hklaw.com

Acknowledgements

Alcatel Submarine Networks

Australian Communications &
Media Authority

British Telecom

Cable & Wireless

Compass Light

Ericsson

Global Marine Systems

Government of Canada

KDDI

LM Glasfiber

Monterey Bay Aquarium
Research Institute

Neptune Canada

NASA

NIWA

NOAA

Porthcurno Telegraph Museum

Seaworks

Submarine Cable Improvement Group

Telecom NZ

Transpower NZ

UK Cable Protection Committee

University of Auckland

University of Massachusetts

University of Wellington



Sharing the seabed in harmony